

Throttle housing Streamlined range

si 0069 GB

Replaces si 0020/A
Replaces si 0040
MSI-PG 08.02

Vehicle: Mercedes-Benz

Type: W201 / W124 / W126 / W107	Engine: M102 / M103	Displacement: 2,0l / 2,3l / 2,6l / 3,0l
------------------------------------	------------------------	--

Product: Throttle housing

Replacement	Pierburg-No.	O.E.-No. *)
7.13835.53.0	7.13835.03.0	A 001 140 82 53
7.13835.54.0	7.13835.04.0	A 001 140 90 53 / A 002 140 06 53
7.13835.55.0	7.13835.05.0	A 002 140 29 53
7.13849.55.0	7.13796.00.0 / 7.13796.01.0 / 7.13796.02.0 / 7.13796.50.0 / 7.13796.51.0 / 7.13796.52.0 / 7.13849.00.0 / 7.13849.01.0 / 7.13849.05.0 / 7.13849.50.0 / 7.13849.51.0	A 002 140 26 53 / A 001 140 60 53 / A 001 140 47 53

We have streamlined our range of throttle housings. In case of replacement, please only specify the above replacement numbers.

Customer complaint:

Hard starting or bucking when accelerating

The listed throttle housings are fitted with a switch for idling and full-load detection (see → arrow in Fig.)

The above complaints can be due to:

- Faulty throttle switch
For testing the switch → see below
- Worn throttle shaft (vehicles with high mileage)

In both cases, the complete throttle housing must be renewed.

Testing the throttle switch

- Connect ohmmeter to terminals 1 and 2 (see → Fig.)
- Move throttle into idle position
Required value: < 1 Ω
- Lift throttle by 0.2 mm from the stop screw
Required value: ∞ Ω
- Connect ohmmeter to terminals 2 and 3 (see → Fig.)
- Move throttle to full load
Required value: < 1 Ω
- Turn throttle slightly towards idle position
Required value: ∞ Ω

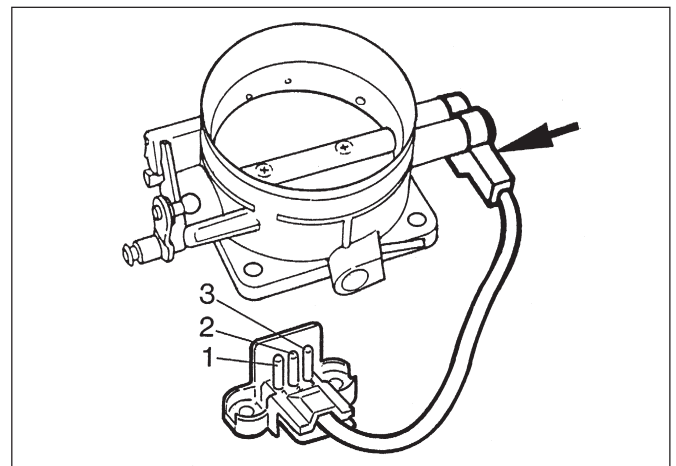

Fig: Throttle housing of a similar type



For the aforementioned vehicles, the throttle housings of a different manufacturer were partly used.

In case of replacement, only the throttle housing from Pierburg is supplied.

Air supply

*) The reference numbers given are for the purposes of comparison only and must not appear on invoices or any other correspondence addressed to the final end-user.